

LCD-S886- Instructions

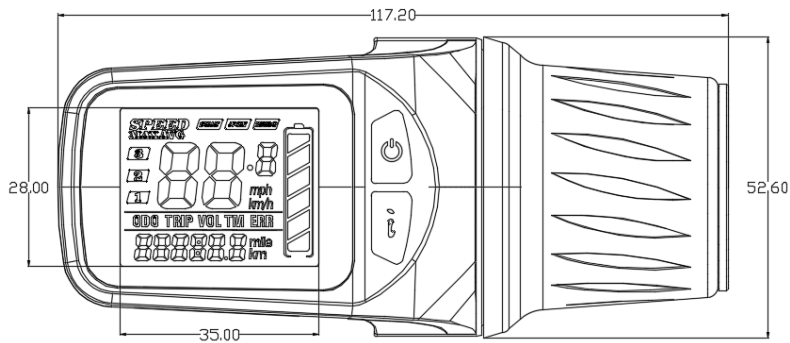

1. Appearance size and Material

The outer shell of the product is ABS and the transparent window is imported high hardness acrylic, the hardness value is equivalent to tempered glass.



Front view

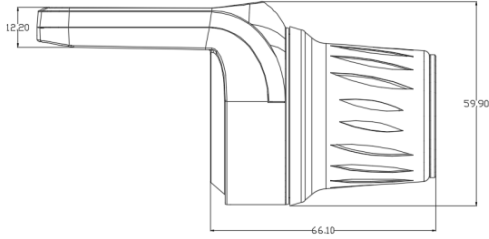

Side view

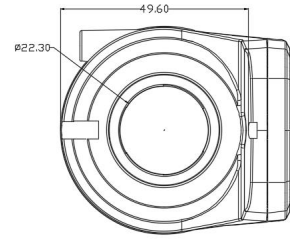

Shifter support

2. Working voltage and Connection mode

2.1 Working voltage: DC24V、36V、48V、60V Compatibility;
Other voltages can be customized.

2.2 Connection mode:

Wiring sequence of standard connectors

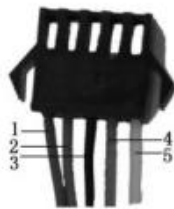

Connect to the controller



Instrument outlet part



docking part

Chart: List of wiring sequence of standard connectors

Wiring sequence of standard connectors	Color	Function
1	Red(VCC)	Instrument power cord
2	Blue(K)	The power line of the controller
3	Black(GND)	Instrument ground wire
4	Green(RX)	The data receiving line of the instrument
5	Yellow(TX)	The data sending line of the instrument

Note: the leads of some products are waterproof connectors. Users cannot see the color of the leads in the wire harness.

3.3.2 Multifunctional display area

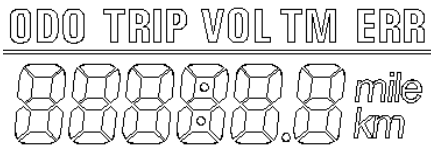

ODO (Unit: mile、km) 、
 TRIP、
 current voltage VOL、
 run time TM、
 fault codes ERR

Fault Codes (Decimal)	Fault state	Notes
E02	Brakes	
E06	Low battery voltage	
E07	Motor fault	
E08	Shifter fault	
E09	Controller fault	
E10	Communication reception fault	
E11	Communication send fault	

3.3.3 Speed display area

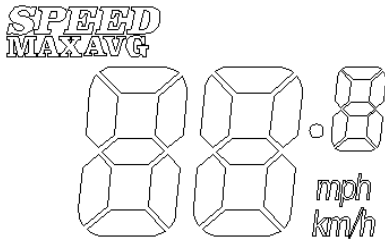

Unit: mph, km/h

The speed signal is taken from the motor inner hall signal and sent to the instrument by the controller, (The time of a single Hall period, Unit: 1MS) The instrument calculates the true speed from the wheel diameter and signal data (The motor hall also needs to set the number of magnetic steels).

SPEED Current speed; **MAX** Max speed; **AVG** Average speed.

3.3.4 Vehicle power gear adjustment

3

2

1

It is adjustable in 1-3 gears.

3.3.5 Zero, Non-zero start display area   ;

 shows Zero start,  shows Non-zero start;

4. Settings

P01: Backlight intensity , the darkest is level 1, the brightest is level 3;

P02: Mileage unit, 0: km; 1: mile;

P03: Voltage classes: 24V, 36V, 48V, default: 36V;

P04: Sleep time: 0, don't sleep; other figures are sleep time;

Range: 1-60; Unit: minute;

P05: Power gear: 0: 3gears mode;

P06: The wheel diameter: unit: inch; precision: 0.1;

P07: Speed measurement of magnetic steel number: Range: 1-255;

P08: The speed limit: Range 0-100km/h, 100 means no speed limit;

1.Communicate status (Controller control) : The input data here represents the maximum running speed of the vehicle: For example, enter 25, means the maximum running speed of the vehicle will not exceed 25km/h; the drive speed is maintained at the set value;

Error: ± 1 km/h; (Power, Shifter all limit speed)

Note: the value here is based on kilometers. When the unit set is convert from kilometers to miles, the speed value of the display interface will automatically convert to the correct value of miles. However, the speed limit value data set in this menu under the mile interface is not converted, which is inconsistent with the actual speed limit value displayed;

Notice: P09-P15 menu is valid only in the communication state.

P09: Zero start、Non-zero start setting, 0: Zero start; 1: Non-zero start;

P10: Drive mode setting:

0: Power drive (How much power is output is determined by the power tap, and shifter is invalid at this time).

1: Electric drive (through the shifter drive, power gear is invalid at this time).

2: Power drive and electric drive coexist (power gear and shifter drive both work).

P11: Power sensitivity setting 1-24;

P12: Power start intensity setting 0-5;

P13: Power magnetic steel disk type setting 5, 8, 12grain magnetic steel type;

P14: Set the current limit of the controller, default: 12A , range: 1-20A;

P15: Controller under-voltage value;

P16: ODO Reset , long press the button to clear ODO for 5 seconds;

P17: 0: Cannot make a cruise, 1: Can make a cruise; Automatic cruise optional (valid for Protocol 2 only)

P18: Display speed proportional adjustment Range: 50%~150%;

P19: Gear 0, 0: containing 0 gear, 1: not containing 0 gear;

P20: 0: Protocol 2; 1: Protocol 5S; 2: standby 3: standby

5. Button introduction:

5.1 When it is power-off state, long press **⏻** button to start;

after start, short press **⏻** button, interface will switch in ODO、TRIP、VOL、TM、ERR.

5.2 When it is power-on state, long press **⏻** button to close, and short press **ⓘ** button to adjust the power gear.

5.3 Long press **⏻** + **ⓘ** button enter into mode setting.

In the setting interface, short press **⏻** button to switch parameter,

long press **⏻** button to switch **ⓘ** button's function of add/subtract;

Parameter modification:

In some parameter state, short press **⏻** button to switch parameter,

short press **ⓘ** button to add or subtract value.

After modification, short press **⏻** button to switch to the next parameter, and save the previous parameter value; after parameter modification, long press **⏻** + **ⓘ** button again to exit setting interface or wait 8 seconds to automatically exit and save the parameters.

5.4 Crank adjusts the motor speed, and the motor speed increases by turning from top to bottom; and let it go then return to zero.